

FOR EXISTING RESERVOIR INSTALLATION, CUT & REMOVE EXISTING 6" SAMPLE PORT PIPE AS SHOWN. WELD 11" ϕ x 1/4" THK. STAINLESS STEEL FLANGE W/ HOLE CUT TO FIT EXISTING 6" PIPE O.D., DRILL (4) 7/8" ϕ BOLT HOLES @ 9" BOLT CIRCLE SPACED @ 90° APART TO MATCH NEW 6" SAMPLE PORT FLANGE.

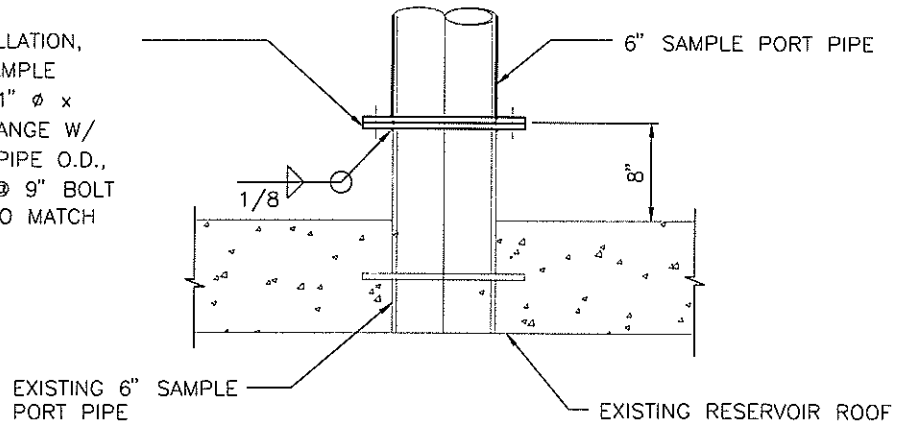

NOTE:

MATERIAL FOR PIPE, PLATE, BAR, FITTINGS, AND ALL HARDWARE TO BE TYPE 316, STAINLESS STEEL, UNLESS OTHERWISE NOTED.

SAMPLING PORT DETAIL

NOT TO SCALE

RS12-5A 060805

