

ANCHOR INSTALLATION

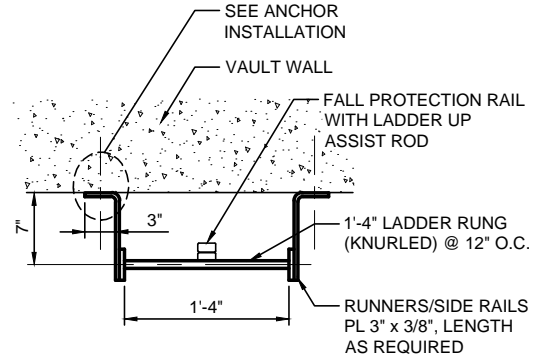

LADDER IN VAULT

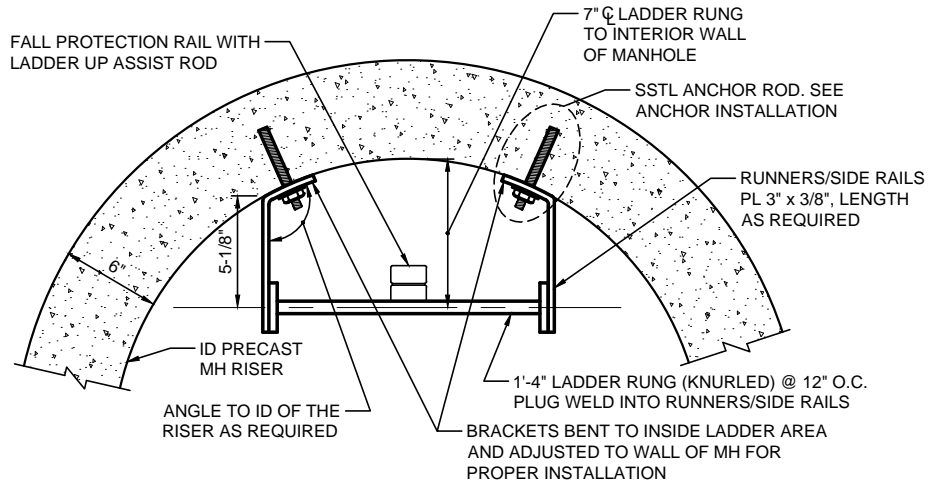

LADDER IN MANHOLE

FLAT BAR SIZE	
LADDER LENGTH	FLAT BAR SIZE
5'-0" TO 20'-0"	3" x 3/8"
OVER 20'-0"	4" x 1/2"

NOTES:

1. ANY BRACKET SPACING OVER 5'-0" OC MUST BE SIGNED AND STAMPED BY A NEVADA REGISTERED CIVIL OR STRUCTURAL ENGINEER
2. LADDER SHALL BE MADE OF MILD CARBON STEEL WITH 3/4" DIA BAR RUNGS (KNURLED) PLUG WELDED TO RUNNERS.
3. HOT DIP GALVANIZE LADDER ASSEMBLY AFTER WELDING.

LADDER INSTALLATION DETAILS

NOT TO SCALE

PL05-6 050626

